

# Manual for trays with feet

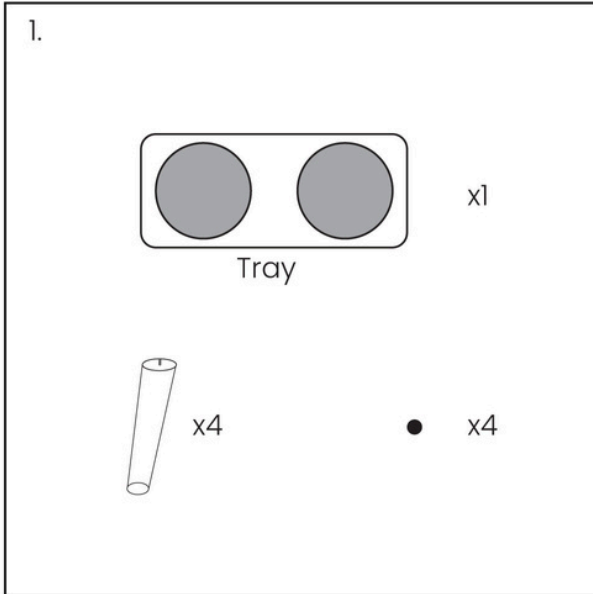

Check if all parts are present:

- 1x tray
- 4x feet
- 4x anti-slip studs

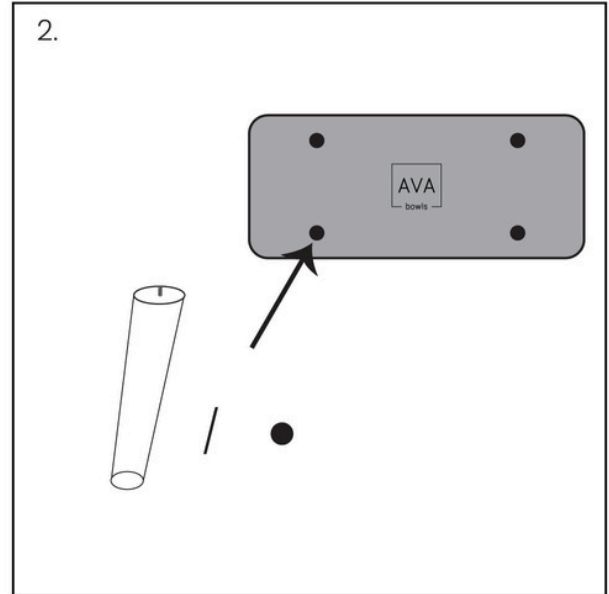

The legs and screw holes are numbered. Attach the 4 legs into the 4 screw holes with a twisting motion.

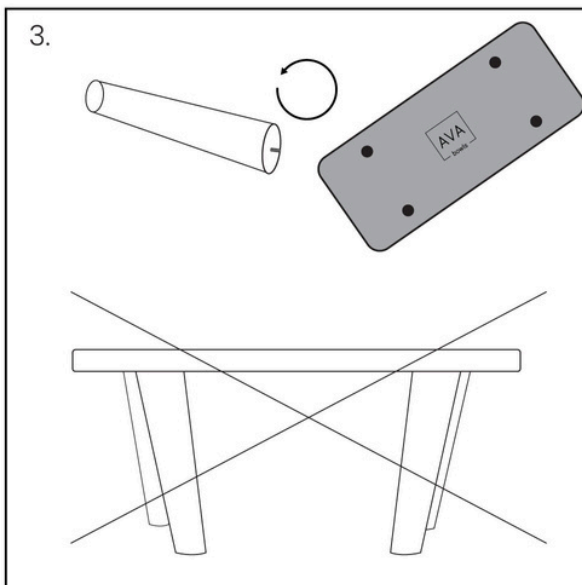

Rotate the legs until they are in the correct and stable position.

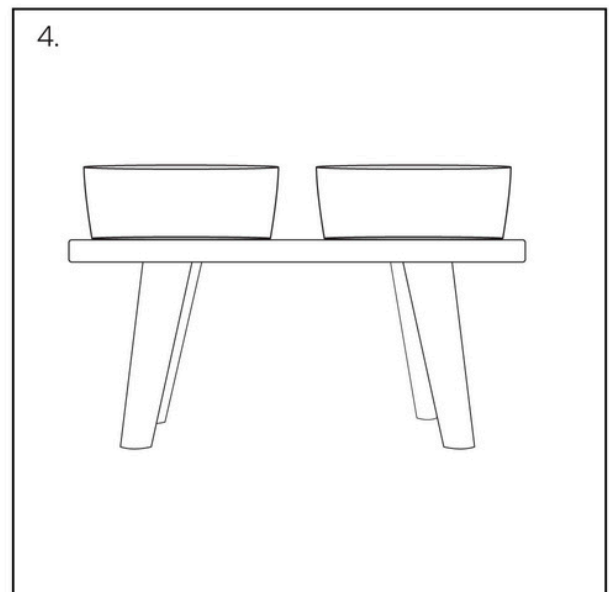

Attach the 4 anti-slip studs under the legs and the tray is ready to use.

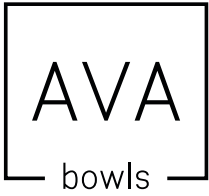

## Maintenance tips oak trays

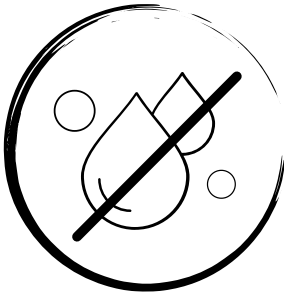

Avoid contact with water as much as possible. Your four-legged friend is bound to spill water while drinking, but then make sure it doesn't stay there too long to avoid stains or tears.

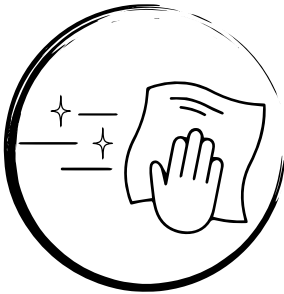

Clean the board regularly.

Tip: Squeeze half a lemon on the board and sprinkle with sea salt. Let this soak in for 15 minutes. This combination kills bacteria and absorbs unwanted odor and stains. Clean with a wet cloth and then dry thoroughly.



Oil the board every 1-2 months with a natural oil approved for food contact to keep the board in good condition. See also AVA bowls' maintenance oil made specifically for this purpose.